

Valvola a sfera K flangia- filetto DIN

K ball valve flange - DIN male end

K Kugelventil Flansch - DIN G

Vanne à boule K bride - mâle DIN

Válvula de bola K brida - macho DIN

AISI 304 - 316

DN	A	B	C	D	E	F	G	H	L
25	96	Rd52x1/6"	85	24	73.5	14	115	4	122
32	96	Rd58x1/6"	100	33	79	18	140	4	122
40	110	Rd65x1/6"	110	40	95	18	150	4	180
50	110	Rd78x1/6"	125	49.5	100.5	18	165	4	180
60	124	Rd84.5x1/6"	145	57.5	107.25	18	185	4	205
65	124	Rd95x1/6"	145	65.5	125.5	18	185	4	266
80	162	Rd110x1/4"	160	79	136.5	18	200	4	266
100R	216	Rd130x1/4"	180	89	144.5	18	220	8	266

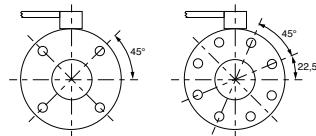
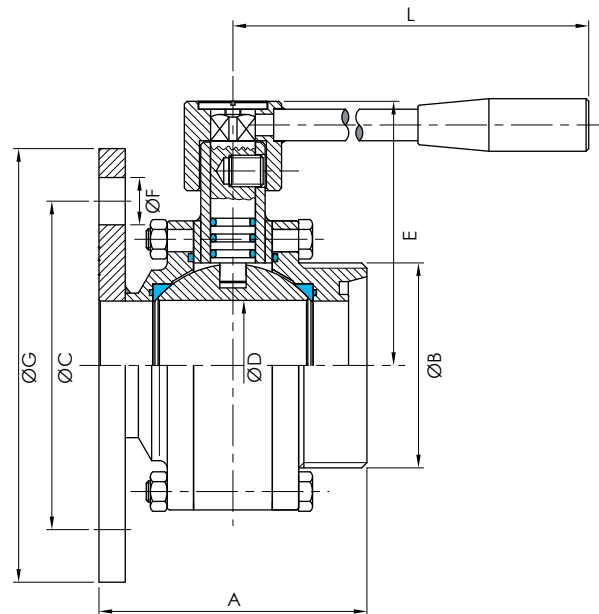
 Posizione dei fori flangia rispetto alla valvola
 Position of the flange holes welded to the valve

Valvola a sfera K a saldare DIN

K ball valve welding ends

K Kugelventil DIN S/S

Vanne à boule K bouts lisses DIN

Válvula de bola K soldar DIN

AISI 304 - 316

DN	A	B	C	D	E	F
25	88	31	31	24	73.5	122
32	88	37	37	33	79	122
40	102	43	43	40	95	180
50	102	55	55	49.5	100.5	180
60	114	63	63	57.5	107.25	205
65	124	72	72	65.5	125.5	266
80	152	87	87	79	136.5	266
100R	154	101.6	101.6	89	144.5	266

